

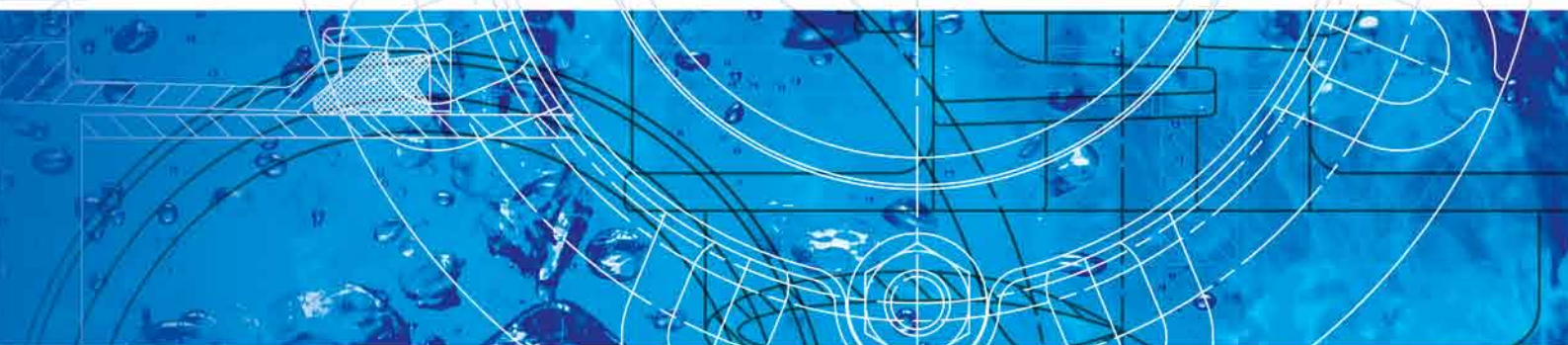

Technical

Design Data

Advanced Solutions for Pipe Technology



PIPE CONNECTIONS, REPAIR & FLOW CONTROL PRODUCTS FOR THE UTILITIES INDUSTRY

Contents

Glossary of Terms	3
Glossary of Standards	4
Design Specifications	5
The Concept	6
System Overview	7
Angular Deflection	8 - 9
Setting Gaps	10
Pressure Forces / Coupling Movement Under Pressure	11
Accommodating End Load Forces / FlexLock / UltraGrip / Dismantling Joint	12
Pipe Supports / Anchored Couplings / Cathodic Protection	13
Locating Plugs / Inclined Pipelines	14
Shear Strength / Expansion & Contraction / Pipe End Preparation	15
Couplings & Stepped Couplings	16 - 17
Flange Adaptors	18 - 19
Gaskets	20 - 21
Corrosion Protection	22
Chemical Resistance Chart	23

Important Notice

The technical, performance data, specifications, dimensions and all other information published in the Design Data section supersede all previously published information.

All data contained herein is subject to change without notice.

The information given in the following pages is intended as a general guide to the proper design and installation of practical piping systems using Viking Johnson products. It is not intended as a substitute for competent, professional advice, which should always be sought in the design of any piping system. Good piping practice should always prevail and recommended design pressures, temperatures, tolerances and loads should never be exceeded.

Special conditions often exist for which the information given here is not specifically suited and specialist engineering advice should be obtained. As with any other piping system, the specific advantages and limitations of Viking Johnson products should be considered when designing a system using Viking Johnson products. The suggestions made here do not set out to give specific solutions to actual installation problems but to give ideas on which to base your own unique solutions.

While every effort has been made to ensure its accuracy, Viking Johnson make no express or implied warranty of any kind in respect of the information contained in this brochure or the materials referred to herein. Any person making use of the information contained here does so entirely at their own risk and assumes any and all liability resulting from such use.

The information contained within this section applies specifically to Viking Johnson products only, and is not intended to apply to any other bolted sleeve type coupling product.

© 2012 by Viking Johnson.

No part of this directory may be reproduced, stored or transmitted, in any form or by any means, electronic, mechanical, photocopying, recording or otherwise, without prior permission.

Glossary of Terms

The following abbreviations are used in this brochure:

OD	-	Pipe outside diameter
NB	-	Nominal bore
DN	-	Nominal diameter, in millimetres
PN	-	Nominal pressure, in bar (1 bar = 0.1 MPa = 0.1 N/mm ² ≈ 14.5 lbf/in ²)
CI	-	Grey cast iron
DI	-	Ductile iron
PE	-	Polyethylene
MDPE	-	Medium density polyethylene (PE80)
HDPE	-	High density polyethylene (PE100)
AC	-	Asbestos cement
GRP	-	Glass reinforced plastics
uPVC	-	Unplasticised polyvinyl chloride
PVC-u	-	Metric uPVC pipe (including Molecular Oriented and Impact Modified)
ABS	-	Acrylonitrile butadiene styrene
EPDM	-	Ethylene propylene diene monomer
NBR	-	Nitrile butadiene rubber
WRAS	-	Water Regulations Advisory Scheme
PCD	-	Pitch circle diameter
SDR	-	Standard diameter to wall thickness ratio

Glossary of Standards

Glossary of Standards

The following standards are used in this brochure:

- ANSI B16.1 - Specification for cast iron pipe flanges and flange fittings
- AWWA/ANSI C219 - Specification for bolted, sleeve type couplings for plain ended pipes
- BS 10 - Specification for flanges and bolting for pipes, valves and fittings
- BS 750 - Specification for underground fire hydrants and surface box frames and covers
- BS 4504 - Specification for circular flanges for pipes, valves, fittings, PN designated
- BS EN 681 - Specification for elastomeric seals. Material requirements for pipe joint seals used in water and drainage applications. Part 1: Vulcanized rubber
- BS EN 682 - Specification for elastomeric seals. Materials requirements for seals used in pipes and fittings carrying gas and hydrocarbon fluids
- BS EN 1074-2 - Specification for Isolation valves for water supply. Fitness for purpose requirements and appropriate verification tests.
- BS EN 1074-6 - Specification for Hydrants for water supply. Fitness for purpose requirements and appropriate verification tests.
- BS EN 1092-1 - Specification for flanges and their joints. Circular flanges for pipes, valves, fittings and accessories, PN designated. Part 1: Steel flanges
- BS EN 14339 - Specification for underground fire hydrants
- BS EN 14525 - Specification for ductile iron wide tolerance couplings and flange adaptors for use with pipes of different materials
- BS EN ISO 9001 - Quality management system requirements
- BS EN ISO 14001 - Environmental management systems requirements
- ISO 7005 - Specification for metallic flanges Part 1: Steel flanges
- ISO 14236.2 - Specification for plastic pipes and fittings – mechanical joint compression fittings for use with polyethylene pressure pipes in water supply systems
- WIS-4-24-01 - Specification for mechanical fittings and joints including flanges for PE pipes for the conveyance of cold potable water for the size range 90-100 made of metal or plastics or a combination of both
- WIS-4-52-03 - Specification for anti-corrosion coatings on threaded fasteners

Design & Specifications of Piping Systems

The Viking Johnson system is suitable for an enormous range of pipework applications and it is therefore impossible to give a comprehensive list of potential uses. In general terms, the system is suitable for virtually any pipeline, above or below ground level, working within the following typical parameters:

Working Pressure

Up to 100 bar (1450psi), according to size and type of product. Up to full vacuum. Higher pressures are available on request.

Temperature

Limited by gasket grade used, but within the range -60°C to +200°C (-75°F to +390°F)

Note: At elevated temperatures, accelerated gasket relaxation will occur, leading to reduced life of fitting

Suitable for

Water, gas, oil, petrochemicals, sewage, powdered solids, granular solids, air. Subject to gasket grade used and product/pipe limitations.

Location

Above or below ground (subject to certain limitations according to product type and pipe material).

Backed by many years of design and manufacturing experience, the Viking Johnson system is a complete and cost-effective answer to almost all pipeline installation problems.

Compare the following benefits with those offered by alternative pipe jointing systems:

- ▶ ISO 9001 certification is proof of our exacting quality standards.
- ▶ ISO 14001 certification is proof of our environmental credentials.
- ▶ Exclusive Viking Johnson gaskets, moulded to exacting specifications, assure perfect lifetime sealing, meeting all relevant Standards.
- ▶ Size range extends from DN15 (0.5") to more than DN5000 (200").
- ▶ The Viking Johnson system is designed for plain-ended pipes, eliminating threading, bevelling, welding or flanging.
- ▶ The system can joint most types of pipes, valves or meters.
- ▶ By specifying Viking Johnson, installation delays caused by adverse weather conditions are overcome, particularly relevant to PE installation.
- ▶ You can rely on Viking Johnson products. Their dependability has been demonstrated for more than 75 years in all conditions of service.
- ▶ On-site jointing equipment - with Viking Johnson products all you need is a spanner and a torque wrench.
- ▶ The simplicity of our design assures you of couplings which will assemble quickly, easily and accurately every time. Company representatives are available to offer technical advice to the installer.
- ▶ As a mechanical jointing system it can eliminate the need for specialist labour or on-site fabrication.
- ▶ Viking Johnson couplings are protected against corrosion with a range of specialised coatings. Please state coating required when ordering.
- ▶ Viking Johnson has over 100 agents and distributors worldwide, in addition to an exclusive distributor network throughout the UK.

The Concept

All Large Diameter Dedicated Viking Johnson couplings, stepped couplings, flange adaptors, MaxiFit, QuickFit, MegaFit, UltraGrip, FlexLock and AquaGrip (up to DN180) operate on the same basic compression principle.

How it Works

The Viking Johnson coupling (Fig. A) comprises a centre sleeve located between two end rings. Wedge-shaped elastomeric gaskets separate the sleeve and end rings. As the captive 'D' head bolts are tightened, the end rings are drawn together, compressing the gaskets between the end rings and the centre sleeve onto the surface of the pipe to form an effective, leak-proof seal (Fig. B).

Fig. A

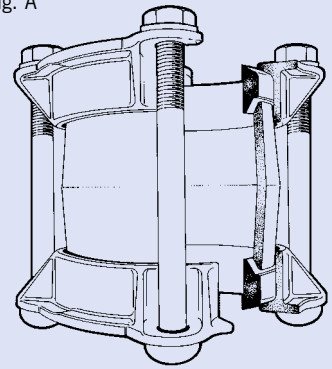

Cutaway illustration of Viking Johnson straight coupling.

Fig. B

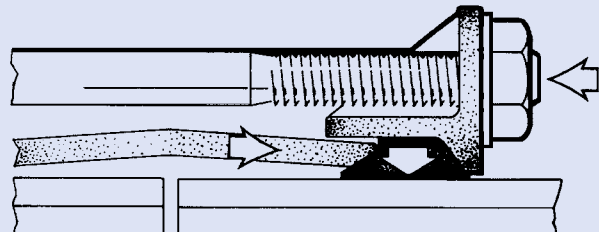

Tightening the bolts compresses the gasket between the end ring and the centre sleeve, forcing the gasket to seal onto the pipe surface.

Fig. C

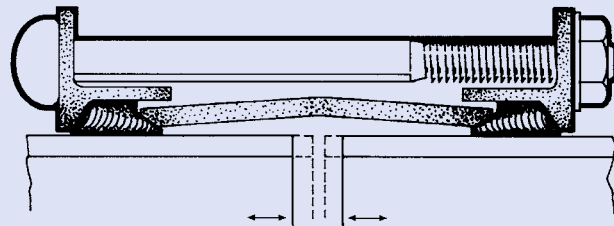

Gaskets deform to accommodate expansion and contraction.

Fig. D

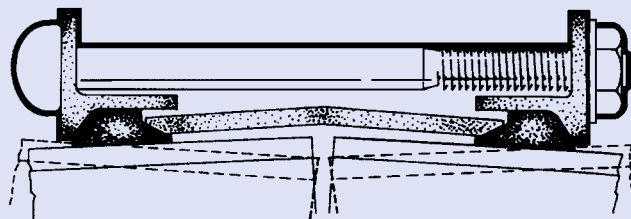

Flexible gasket and centre sleeve clearance allows angular movement.

Features

The basic concept of the Viking Johnson coupling means that it can be used on plain-ended pipe, removing the need for costly and time-consuming pipe end preparation. The Viking Johnson coupling is also capable of absorbing expansion and contraction which occurs in pipelines as a result of temperature fluctuations, without the need for special expansion joints (Fig. C). In addition, it can accommodate enough angular deflection to allow for pipeline movement or ground settlement, or to provide for long radius curves without the necessity of incorporating purpose-made bends (Fig. D).

Pipe Materials

Most rigid and semi-rigid pipe materials can be joined with Viking Johnson coupling products:- steel (including stainless steel), grey cast iron, ductile iron, asbestos cement, uPVC, GRP, concrete, polyethylene and ABS.

Of these, the rigid materials with high strength capabilities, such as steel, grey cast iron, ductile iron and concrete can be joined using standard Viking Johnson couplings without revision to our normal fitting instructions.

Certain lower strength materials, such as clayware and the lower classes of asbestos cement pipe, may need reduced bolt torques to avoid pipe damage. Glass reinforced plastic (GRP) pipe is relatively flexible and its structure may be damaged by high gasket pressures. Reduced bolt torques are also recommended for this pipe material (details available on request).

Polyethylene (PE) pipe is produced in various types and with various performance capabilities. All exhibit the tendency to creep i.e. change shape when loaded. The use of standard Viking Johnson couplings may result in leakage or pipe pull-out. Viking Johnson AquaGrip and AquaFast products are both specifically designed to join PE pipe either to another PE pipe or to flanged equipment or other pipe materials. Certain sizes of EasiClamp are also suitable for use on repairs to PE pipe. UltraGrip may be used on PE pipe if a supporting internal liner is also used.

Pipe Outside Diameters

Dedicated Viking Johnson couplings and flange adaptors may be specified for any pipe size between DN50 (2") and DN5000 (200"), even for outside diameters not covered by recognised pipe standards. Since Viking Johnson couplings fit over the outside of the pipe, it is essential that the OD is specified at time of enquiry/order.

Pipe Tolerances

Viking Johnson couplings give their optimum performance when they are a close fit on the pipe. Seal effectiveness depends on the pressure which the gasket applies to the pipe surface. Undersized pipes may mean a loss in pressure rating.

Many pipe standards quote the main pipe barrel tolerance separately from the tolerance on the pipe ends.

Unless otherwise informed, Viking Johnson products are designed to accommodate the pipe end outside diameter and associated tolerance from the relevant industry specification for the pipe material concerned. In the event that the pipe outside diameter and tolerances are not in accordance with the standard then guidance should be sought from Viking Johnson on how these can be accommodated in our products.

Pipe Ovality

Moderate ovality, especially in large diameter steel or ductile iron pipes, can frequently be rectified by selective bolt tightening to give a uniform annular gap between pipe and coupling. More severe ovality, up to a limit of about $\pm 1\%$ of diameter, may be corrected by jacking, taking care not to damage the internal lining of the pipe.

Pipes having local stiffening near the ends may be impossible to correct or shape by these methods and good circularity is essential if couplings are to be fitted successfully.

N.B. The Viking Johnson MaxiFit, MegaFit and UltraGrip ranges of Universal Coupling products can accommodate larger pipe tolerances and ovality, see separate brochures for details.

Diameter Measurement

The most reliable method of measuring OD is by circumference measurement. This eliminates the effects of ovality and, provided that ovality is moderate, it is almost always possible to correct during assembly. Circumference measurement may be carried out using either a purpose-made circumference tape which reads out directly as an effective diameter, or it is possible to use an ordinary tape wrapped around the pipe and the resulting circumference value converted to effective diameter by dividing the result by $\pi (= 3.142)$.

If pipe calipers are available, these can give a useful further indication of pipe shape and the possible need for special sizing of the coupling. If in doubt, contact Viking Johnson for further advice.

Pipe Coatings

Many pipes are finished with a coating of some description, which can affect pipe O.D. Allowance must be made for these coatings in the manufacturing size of the coupling, or installation of the coupling may be difficult or impossible. Very thick pipe wrappings (typically several millimetres thick) must be removed at pipe ends so that the coupling will seat either on the bare pipe or on a high quality thinner paint film. It is important that details of the intended pipe corrosion protection are made known to us when ordering so that the correct size of coupling can be produced. Alternatively, we must be informed of the finished pipe diameter including all coatings, with appropriate tolerances.

Pipe Surface Finish

The Viking Johnson system relies on good uniform contact of the gaskets with the pipe surface.

It is important to ensure that the pipe ends, in the areas where the coupling gaskets will seat, are free from loose surface deposits, bumps, dents, score marks, weld beads, flat spots and the like, or the full pressure capability of the coupling may not be realised.

Working Pressure

The working pressure capability of a coupling varies with its size and construction. It is also dependent upon correct pipe tolerances and surface finish. Wider pipe OD tolerances than those specified will result in a reduction in pressure capability. For most pipe materials, the actual test pressure will be lower than that of the coupling and will be determined by the pipe capability or class. Similarly the pressure rating of a flange adaptor will be determined by the rating of the main flange (eg. PN16 = 16 bar working pressure, 24 bar test).

When assembled onto the pipe(s), the pressure rating of the completed assembly will be that of the lowest rated component. Under normal circumstances working pressures are up to 2/3 of the maximum test pressure shown in any Viking Johnson literature appropriate schedule.

Operating Temperature

The operating temperature of Viking Johnson couplings is determined by the temperature rating of the gaskets and on coating type. Different grades of gaskets are available to suit various temperature ranges as well as different chemical resistance requirements. For details see the Gaskets section (pages 20-21). Most Viking Johnson Couplings are supplied with Rilsan Nylon 11 coating which has a maximum operating temperature of 90°C.

For higher temperatures, alternative coatings may be necessary.

Viking Johnson couplings operate at their maximum efficiency under conditions of relatively constant temperature. If temperature fluctuations occur or at elevated temperatures $> 60^\circ\text{C}$, retightening of the bolts may be required. For this reason, where maintenance-free operation is required, Viking Johnson couplings are not recommended as a pipe jointing system for central heating or similar systems which do not operate at a relatively constant temperature.

Chemical Resistance

The chemical resistance of a Viking Johnson coupling is determined by suitability of the gaskets and by the chemical resistance of the internal surfaces of the coupling sleeve. If the coupling is coated with Rilsan, epoxy, etc. it is necessary to ensure that this material is chemically suitable for contact with the pipe contents. Chemical resistance of the gaskets and coatings may be checked with the chart on page 238 or by contacting Viking Johnson.

Angular Deflection

Fig. 1.1

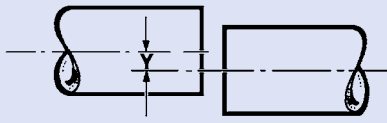

Lateral displacement (Y) can be accommodated using two couplings.

Fig. 1.2

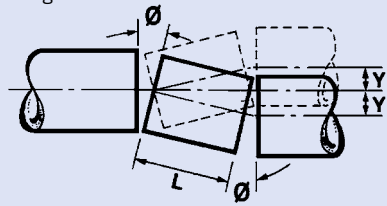

Length of closing pipe (L) depends on maximum angularity (θ).

Fig. 1.3

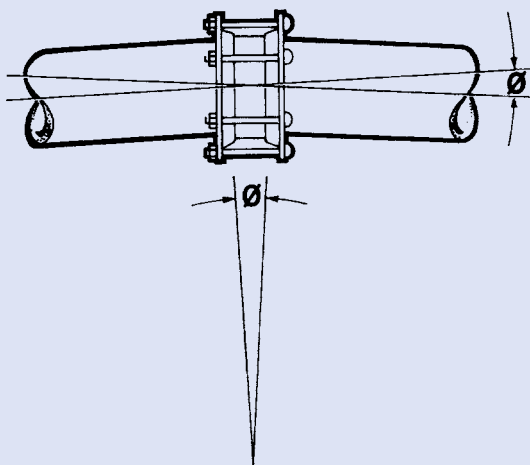

Angular deflection (θ). Up to 6° in smaller pipes, reducing to 1° in larger diameters.

Each dedicated Viking Johnson coupling or flange adaptor will allow for a setting angularity (θ) as shown in Table 1.1.

The ability of Viking Johnson couplings to accommodate angular deflection, either on installation or in service, can be used in a number of valuable ways:

- a) To take up minor misalignment or lateral displacement in straight pipes, eg. at closing lengths.
- b) To accommodate ground settlement.
- c) To lay pipes to long radius curves without special bends.

a) Lateral Displacement

Lateral displacement between two pipes can be easily accommodated using two couplings and an appropriate length of closing pipe which can be allowed to angulate (Fig 1.1 & 1.2).

A SINGLE COUPLING CANNOT ACCOMMODATE LATERAL DISPLACEMENT.

The length, L, of the closing pipe can be calculated from the closing length Table 1.2.

b) Ground Settlement

Ground settlement, for example where a pipe leaves an underground structure, may be accommodated using a pair of Viking Johnson couplings. In this case, pipe trenches are excavated below the pipe invert to allow for pipe bedding. If this bedding is to be flexible (eg. granular fill), some settlement will inevitably occur when the trench is backfilled. (Fig. 1.4)

To minimise stresses in pipe 1, coupling A should be installed as close as possible to the structure. The two couplings A and B allow pipe 2 to angulate to take up settlement Y. The minimum length of pipe 2 is determined using the Closing Length Table in Table 1.2. The structural strength of the pipe in bending may need to be considered.

Alternatively, a Viking Johnson wall coupling can be used instead of pipe 1 and coupling A.

Table 1.1

SETTING ANGULARITY TABLE - DEDICATED RANGE		
Coupling Size	Angle	Inclination
Up to DN450 (18")	± 6°	1 in 10
Over DN450 - DN600 (18" - 24")	± 5°	1 in 12
Over DN600 - DN750 (24" - 30")	± 4°	1 in 15
Over DN750 - DN1200 (30" - 48")	± 3°	1 in 20
Over DN1200 - DN1800 (48" - 72")	± 2°	1 in 30
Over DN1800 (72")	± 1°	1 in 60
Flange Adaptor Size		
Up to DN450 (18")	± 3°	1 in 20
Over DN450 - DN600 (18" - 24")	± 2.5°	1 in 24
Over DN600 - DN750 (24" - 30")	± 2°	1 in 30
Over DN750 - DN1200 (30" - 48")	± 1.5°	1 in 40
Over DN1200 - DN1800 (48" - 72")	± 1°	1 in 60
Over DN1800 (72")	± 0.5°	1 in 120

The above schedules represent the maximum angular deflection for each size range and should only be used when the pipes will not move in service. For other conditions it is recommended to halve these figures to allow for in-service flexibility.

Angular Deflection

Pipe Nominal Diameter	L, Minimum Length (mm)
Up to DN450 (18")	Displacement Y x 10
Over DN450 - DN600 (18" - 24")	Displacement Y x 12
Over DN600 - DN750 (24" - 30")	Displacement Y x 15
Over DN750 - DN1200 (30" - 48")	Displacement Y x 20
Over DN1200 - DN1800 (48" - 72")	Displacement Y x 30
Over DN1800 (72")	Displacement Y x 60

EXAMPLE: Pipe OD = 711mm
 Lateral displacement to be accommodated = 90mm
 Minimum closing length = 90 x 15 = 1350mm

EXAMPLE: Pipe OD = 28"
 Lateral displacement to be accommodated = 4"
 Minimum closing length = 4 x 15 = 60"

NOTE: For Viking Johnson flange adaptors these lengths must be doubled.

Fig. 1.4

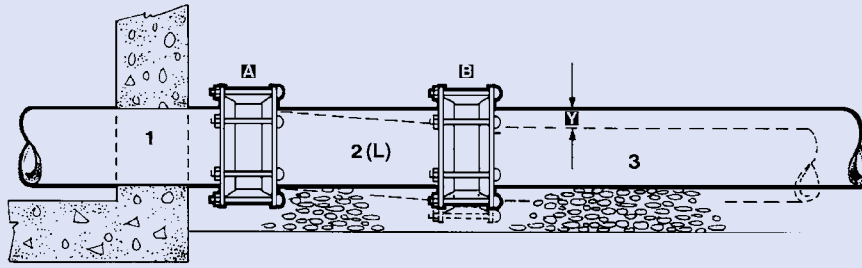

Ground Settlement. Displacement **Y** can be accommodated using two couplings **A** and **B**.

c) Long Radius Curves

Using Viking Johnson couplings it is possible to lay a pipeline to long radius curves, taking a small angular deflection at each coupling, without the need for special large-angle bends with associated thrust blocks. This method can be used to avoid major obstacles on cross-country pipelines or follow the line of roads or streams, etc. using the equation given below.

$$R = \frac{L}{2 \sin 1/2 \phi} \quad \text{Or} \quad \phi = 2 \sin^{-1} \left(\frac{L}{2R} \right)$$

Where L = pipe length
 ϕ = angular deflection
 r = radius of curve

Fig. 1.5

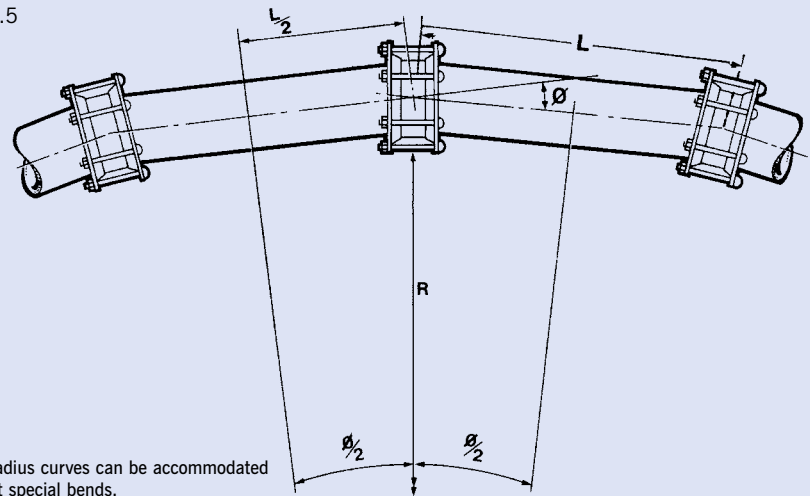

Long radius curves can be accommodated without special bends.

See minimum radius Table 1.3

NB: In an above ground pipeline, lateral pressure thrusts will need to be restrained by the support system. Buried pipes laid to a curve will normally receive sufficient support from the trench backfill material.

Table 1.3

Pipe diameter	MINIMUM RADIUS TABLE					
	<DN450 18"	>DN450-600 18" - 24"	>DN600-750 24" - 30"	>DN750-1200 30" - 48"	>DN1200-1800 48" - 72"	>DN1800 72"
Nominal Angle ϕ	6°	5°	4°	3°	2°	1°
Pipe Length (L)	Minimum Radius (R)					
3m (10ft)	29m (95ft)	34m (110ft)	43m (140ft)	57m (185ft)	86m (280ft)	172m (565ft)
6m (20ft)	57m (187ft)	69m (225ft)	86m (280ft)	115m (375ft)	172m (565ft)	344m (1130ft)
9m (30ft)	86m (280ft)	103m (335ft)	129m (425ft)	172m (565ft)	258m (845ft)	516m (1690ft)
12m (40ft)	115m (375ft)	138m (450ft)	172m (565ft)	229m (750ft)	344m (1130ft)	688m (2260ft)

Other radii may be calculated using the formula given above. **NOTE:** These minimum radii do not allow any in-service movement.

Setting Gap

Viking Johnson couplings are used to join pipes flexibly, so that if there is pipe or ground movement during the life of the pipeline, the coupling will accommodate this without leakage. However, such movement will result in relative longitudinal and/or angular displacement of the pipes within the coupling.

Under normal conditions, adjacent pipe ends should not make contact with each other in service. If there is insufficient gap so that pipes do touch, the pipeline will tend to buckle as temperatures increase and pipe end damage may occur. At the other extreme, if the pipe end gap is too large on installation, there is a risk that pipes may pull out past the gasket(s) of the coupling leading to leakage and failure of the pipeline.

It is therefore necessary to ensure that pipe end gaps are set within specified limits during installation of the coupling to ensure that neither situation occurs.

We give a Recommended Setting Gap for all sizes of Viking Johnson coupling and flange adaptor, which specifies the normal initial gap between adjacent pipe ends such that if the full recommended angularity or expansion occurs in service, the pipe ends should not touch together causing damage. (see Table 1.4)

Similarly, we also give a Maximum Recommended Gap which ensures that even with full recommended angularity there should not be any risk of pipe ends pulling out past the coupling or flange adaptor gasket, leading to leakage.

(see Fig. 1.6 and Table 1.4)

For pipes above ground, it is possible for unanchored pipes to shunt together after installation, opening up a large gap between pipes at certain points. Such pipe movement must be controlled to ensure that the Maximum Permissible Gap is not exceeded, or there may be a risk of the pipe pulling

out of the coupling. Soil friction acting on pipes laid below ground normally prevents any such pipe shunting movement.

The Maximum Permissible Gap, measured on the centreline, should not be exceeded in service. Consideration of actual thermal movement or deflection conditions may lead to different initial setting gaps.

When couplings are specified with a locating plug, the Recommended Setting Gap should be increased by the diameter of the pin or plug (9.5mm or 12.7mm). However, the Maximum Permissible Gap should not be increased.

Where the standard Viking Johnson sleeve length is found to be insufficient, longer sleeved couplings and flange adaptors can be supplied.

Fig. 1.6

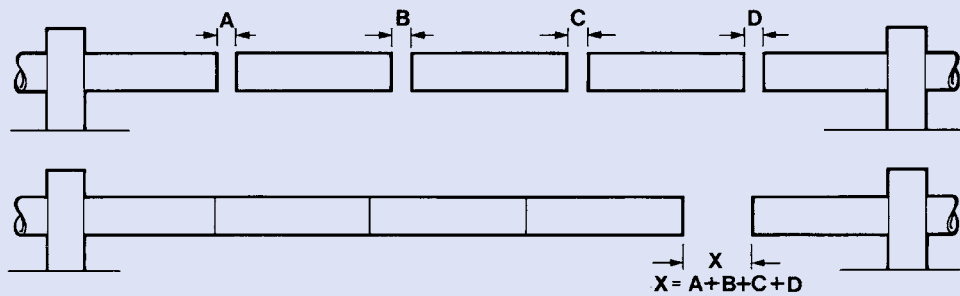

- a) Pipes laid straight with equal setting gaps.
- b) Accumulated gap (X) on straight pipeline must not exceed maximum permissible value given in Setting Gap Table.

Table 1.4

SETTING GAP TABLE				
Coupling Sleeve Width	Nominal Size (D)	Recommended Setting Gap		Maximum Permissible Gap (x)
		Couplings	Flange Adaptors	
100mm	DN50 (2") to DN300 (12")	20mm	20mm	40mm
150mm	DN350 (14") to DN900 (36")	25mm	25mm	50mm
178mm	DN1000 (40") to DN1800 (72")	40mm	30mm	75mm
254mm	Over DN1800 (72")	55mm	55mm	115mm

General guide for dedicated couplings, see fitting instructions related to each product type for further details.

Pressure Forces

All pipelines under pressure are subject to longitudinal forces which tend to separate the component parts of the pipeline. Consider the case of pressure acting on a blank end (Fig 1.7). The force, F, necessary to prevent pipe separation is given by:

$$F = \frac{p \pi d^2}{4}$$

Where d = pipe OD
p = internal pressure.

Example:

d = 508mm OD.
p = 16 bar = 1.6 N/mm²
Then $F = \frac{1.6 \times \pi \times 508^2}{4} =$
324293 N = 324.3 kN =
33.07 tonnes

It is important to appreciate the magnitude of the end thrusts which can result from internal pressure in a pipeline. These longitudinal forces are particularly important in flexibly jointed pipelines, such as those jointed with Viking Johnson standard couplings. The pipeline designer must carefully consider not only the magnitude of these forces but also the means of resisting them to prevent failure of the pipeline.

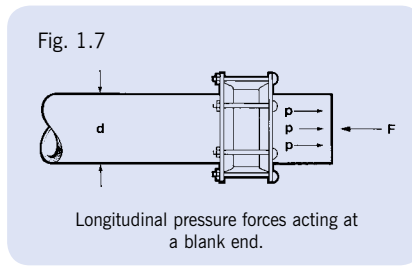

Pressure thrusts will be produced at all changes of direction, eg. bends, tees, etc. and at cap ends, valves and reducers. Unless these thrusts are restrained locally at the point at which they are developed, pipe components may move under the load, leading to failure.

Even small diameter pipes may pull out of couplings at modest pressures unless proper external restraint is provided, especially if the pipe system is subjected to temperature or pressure fluctuations, vibration or external loadings.

With surface or above-ground pipelines it is generally necessary to take full account of the thrusts produced by internal pressures and to restrain them with thrust blocks, anchorages or tie bars. At a bend, there is

a force, R, tending to push the bend outwards (Fig. 1.8).

In this case there must be sufficient anchorage to resist resultant force R. In a buried system a thrust block (Fig. 1.8a) may be used to resist R.

$$R = \frac{p \pi d^2}{2} \sin \frac{\theta}{2}$$

where d = pipe outside diameter

p = internal pressure

and θ = angle of the bend

NOTE: Any consistent set of units is suitable.

VIKING JOHNSON FLEXIBLE COUPLINGS DO NOT RESIST LONGITUDINAL THRUST LOADINGS, AND PIPE PULL-OUT WILL OCCUR UNLESS THE LOADS ARE RESTRAINED BY OTHER MEANS.

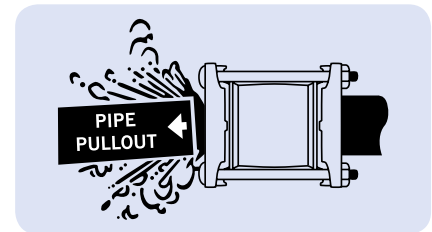
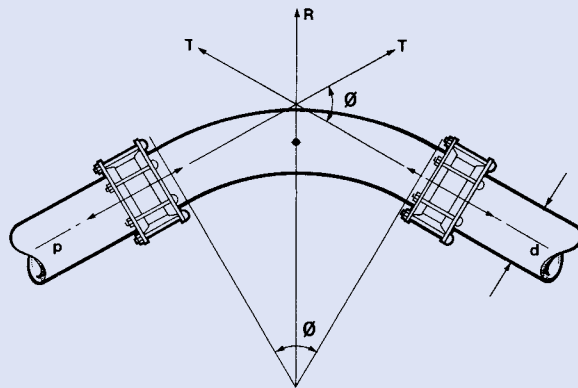
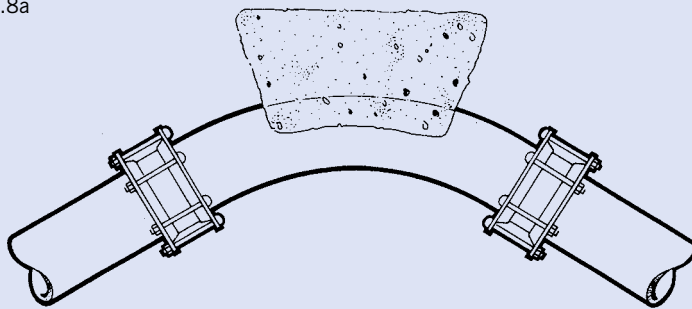

Fig. 1.8



Longitudinal pressure forces acting at a bend.

Fig. 1.8a



Concrete thrust block for retaining bend.

Coupling Movement Under Pressure

Internal pressure will mainly cause pipe movement if there is inadequate restraint. However it can also cause coupling movement. A Viking Johnson stepped coupling is in effect a reducer, and internal pressure will tend to push it towards the smaller diameter pipe. Under normal circumstances, i.e. modest diameter reduction, buried service, standard water pressures etc., soil and pipe friction are sufficient to prevent coupling movement. However, for larger diameter and for above ground service, and in particular higher pressures, the pressure thrust acting on the stepped coupling sleeve can be sufficient to cause coupling movement and consequent disengagement. Positive steps must be taken to restrain the coupling to prevent movement. This may take the form of harness rods, stops on the pipe or within the coupling or encasement in concrete. For further advice, please contact Viking Johnson Technical Support.

Accommodating End Load System

Below ground, pipe thrusts can normally be restrained by means of concrete thrust blocks at bends, valves, etc. However, above ground this is more difficult. In such circumstances it may be necessary to provide a harness assembly, attached to the pipes on both sides of the coupling. This consists of one or more pairs of tie bolts located in either harness lugs welded to the pipe (Fig. 1.9 (a)) or attached by other means, eg. flanges cast on. Accommodating pipe thrusts in above ground applications with Viking Johnson standard coupling products requires either external brackets / pipe supports or the use of harness assemblies attached to the pipe some distance back from each joint. Harness assemblies consist of one or more pairs of tie rods located in lugs / flanges welded to the pipe a short distance away from the joint. The design of the harness lug assembly has to include for the transfer of end load forces via the tie rods into the pipe wall, and it is essential to verify that the interface between the lug and pipe wall is sufficiently strong enough to accommodate these loads. For this reason Viking Johnson deem that the responsibility of the design for the harness lugs lies with the pipe manufacturer and therefore we are not able to include these as part of our product offering.

Use of a single pair of tie rods permits angularity between pipes in one plane, eg. to permit ground settlement.

Flange adaptors can also be prepared for harness assembly. Here, a number of the flange bolts are replaced with long tie bars (Fig 1.9 (b))*.

Harnessed flange adaptors used with a flanged spigot (Fig. 1.9 (c)) give a simple, cost-effective method of providing a demountable joint in an otherwise flanged system. Viking Johnson provide the complete package for Fig 1.9 (c).

When a flange adaptor is harnessed (or a Dismantling Joint used), there will be no resultant angular deflection, or in service expansion capability within the joint, unless special arrangements are specified beforehand.

Fig. 1.9

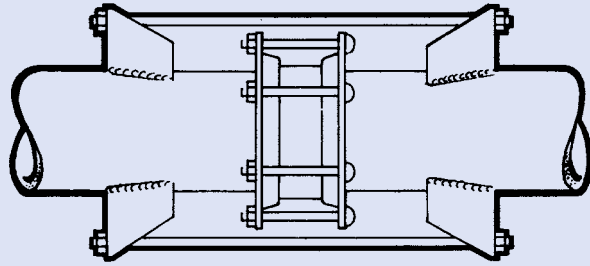

a) Harness assembly for straight or stepped coupling to prevent pipe separation under pressure. (It may be necessary to reinforce the pipe wall locally to the harness assembly to resist pipe distortion.)

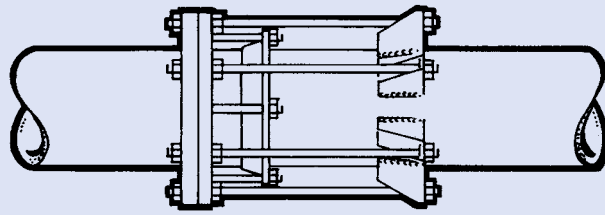

b) Harness assembly with flange adaptor.

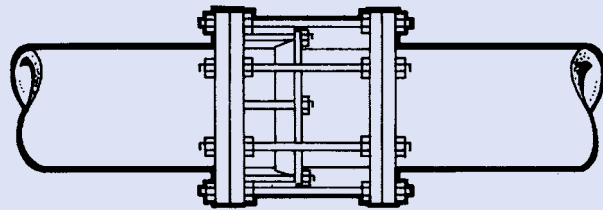

c) Flange adaptor with flanged spigot (supplied complete as the Viking Johnson Dismantling Joint).

** NOTE: If a flange adaptor is to be used in a tied arrangement, it may be necessary to notch the end ring to ensure sufficient clearance for the tie bars. If notified beforehand, Viking Johnson can incorporate notching of the end rings during manufacture. (Please note that the Viking Johnson MaxiDaptor cannot be notched).*

For ductile iron flange systems, it is normally recommended that the end ring is notched to accommodate a number of tie bars equal to half the quantity of main flange bolts. For steel flange systems, this number may be reduced.

Alternative Viking Johnson Products

Viking Johnson has within its comprehensive range specialist products capable of accommodating end load forces these include:-

FlexLock

Dedicated flange adaptors and couplings for steel and ductile iron pipes.

UltraGrip

Wide tolerance couplings, flange adaptors, end caps and reducers for most pipe materials. (For below ground installations)

Dismantling Joint

Double flanged adjustable spool piece in a variety of flanges.

Pipe Support

Pipes laid above ground, usually with supports at specified locations, must transfer all the weight of pipe and contents, plus any pressure-related forces, through those supports.

Fig. 1.10 shows a standard method of supporting a pipeline where subsidence

is expected and which allows freedom of movement within the capabilities of the Viking Johnson couplings while anchoring and supporting the pipes. Alternate pipe lengths are fully supported between two couplings, provided that the clear pipe span does not exceed 10 metres (30ft).

This pipe span distance does not apply to MaxiFit, MegaFit or New QuickFit as anchored couplings. Contact Viking Johnson for details. Intermediate anchors (B) are necessary to prevent any cumulative pipe creep, with full thrust anchors (A) at the ends of long runs or at major changes in direction.

Fig. 1.10

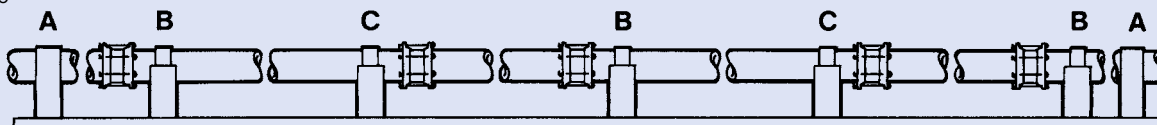

Method of supporting pipes where subsidence is expected.

A. Anchor at end of each straight run. B. Intermediate anchor points. C. Guide supports or cradles.

Anchored Couplings

The Viking Johnson Anchored Coupling (Fig. 1.11) provides an alternative method of supporting pipes above ground. Brackets welded to the centre sleeve of the coupling can be bolted directly to the supporting structure without the need for specially shaped saddles, straps, etc., thus reducing installation costs and greatly improving laying times. The brackets are capable of withstanding the thrust produced by maximum angularity and will support a 10 metre (30ft) long pipe filled with water.

Anchored couplings may be bolted to the structure in any orientation (ie. bolted to a ceiling, side wall, etc.), provided that the pipeline is substantially horizontal. Useful when installing a number of pipes in a confined space i.e. a pipe duct. Anchor brackets are not designed to withstand longitudinal or lateral forces due to external pressure thrusts.

Large diameter (>DN1600/54") or heavy section couplings may require a reinforced saddle around the anchor brackets.

The use of locating plugs with anchored couplings is recommended to help control pipe movement.

(Please note that MaxiFit, MegaFit and New QuickFit couplings are not available, as anchored couplings.)

Fig. 1.11

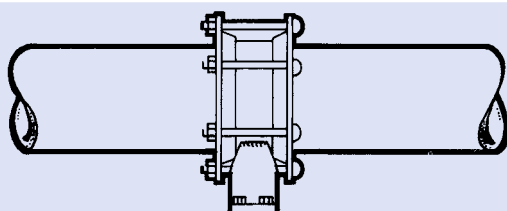

Viking Johnson anchored coupling.

Important:

1. Harness assemblies should not normally be used in conjunction with anchored couplings.
2. Ensure that sufficient clearance is allowed between the coupling and the plinth to permit full assembly of ALL bolts.

Cathodic Protection

If specified, Viking Johnson couplings can be included in a pipe system that is to have cathodic protection. They can be supplied with a threaded stud on the centre sleeve and end rings, such that electrical connections can be made across and including the coupling. Contact Viking Johnson for further details. See Fig. 1.12.

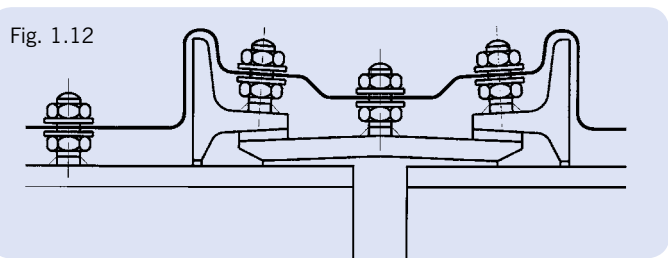

Fig. 1.12

Locating Plugs

Couplings installed above ground may tend to creep along the pipe with repeated pipe movement, temperature variation or vibration. This can be restrained by using couplings fitted with removable locating plugs, which prevent the coupling from moving beyond fixed limits Fig. 1.14.

Removable locating plugs enable single pipe

removal. Once the locating plug is removed, the end rings can be slackened off and the gaskets and centre sleeve can be slid along the pipe to expose the joint. The pipe can then be removed.

Normally it is unnecessary to use locating plugs in couplings below ground since soil friction will ensure that the couplings remain

in their correct position relative to the pipes. However, locating plugs can provide a useful method of coupling centralisation over the pipe ends.

Removable locating plugs are only available on Dedicated couplings.

Removable locating plugs are available Zinc plated or stainless steel.

For Dedicated Viking Johnson couplings, locating plugs are produced in the following standard sizes-

Pipe OD	Thread Diameter	Peg Diameter
up to 914mm (36")	0.25" BSP	9.5mm (0.375")
over 914mm* (36")	0.5" BSP	12.7mm (0.5")

**may be used on smaller diameter heavy section couplings.*

Fig. 1.14

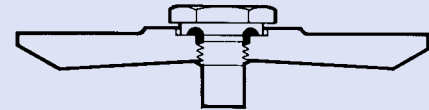

a) Removable locating plug.

Inclined Pipelines

Where Viking Johnson couplings are to be installed in pipelines laid on significant slopes, it is important to consider the restraint of the component of self-weight acting parallel to the axis of the pipeline, to stop the pipe sliding down the slope (Fig. 1.15).

Below ground pipelines will receive significant restraint from backfill loading and therefore less extra axial restraint will be necessary than for above ground pipelines, but the gravity forces still need to be considered in a proper engineering assessment of the design.

On above ground pipelines the Viking Johnson couplings should be fitted with

locating plugs to ensure the coupling's location relative to the pipe ends.

N.B. Locating plugs are not designed to restrain pipe self-weight, axial forces or other pipeline thrusts, only to restrain the coupling itself, ie the pipes must be fixed.

Where the length L of pipe to be supported by the Viking Johnson couplings does not exceed 10 metres (30ft), it is normally desirable to anchor one end, A, of each pipe in position relative to the ground, allowing the other end, B, to be supported by coupling C and to move axially with temperature fluctuations as shown. Its limitations are detailed in Expansion and Contraction (refer to page 15).

Pipeline anchorage must be designed to restrain all axial forces due to self-weight, fluid friction and pressure. The pipe support design will be determined by pipe diameter, pressure, wall thickness, pipe inclination to horizontal, etc and is beyond the scope of this brochure. Certain diameter, pipe length and inclination conditions may necessitate the use of supports on both sides of the coupling. In this instance one support should be fixed, the other sliding to permit thermal movement. It is essential that accurate pipe alignment is observed to prevent excessive shear stress in the coupling.

In certain cases of limited diameter and inclination to the horizontal it may be possible to permit the use of Viking Johnson anchored couplings to both support and restrain the pipes. In this instance the pipe self-weight axial loads are restrained by the coupling locating plug and Viking Johnson should be contacted for specific design recommendations before proceeding.

Fig. 1.15

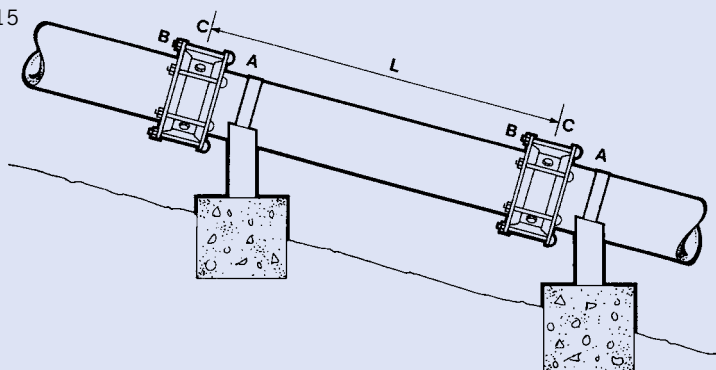

Typical support of inclined pipelines.

Shear Strength

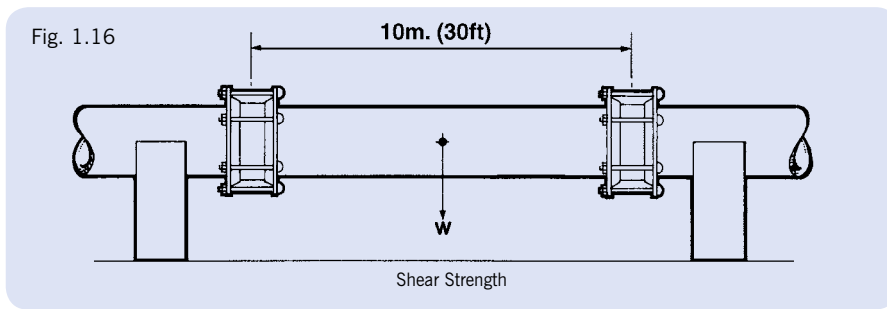

Up to DN1500 (60"), Dedicated Viking Johnson couplings are capable of withstanding a shear force corresponding

to the weight of a 10 metre (30ft) length of water-filled pipe of the diameter for which the couplings were designed, when

supported between two couplings. This also applies to flange adaptors. In the case of stepped couplings the maximum shear resistance is that of the smaller end of the coupling - Fig. 1.16.

External superimposed forces will reduce the maximum clear span. MaxiFit and MegaFit Wide Range couplings are not generally suitable for this duty and the pipe should be adequately supported to prevent sagging and coupling rotation.

Expansion & Contraction

Viking Johnson couplings and flange adaptors can accommodate significant regular expansion and contraction movement in a pipe system, usually enough to remove the need for special expansion jointing products. This is achieved by deformation of the gaskets rather than by sliding on the pipe surface. Most expansion movements due to normal ambient temperature variations can be accommodated using Viking Johnson couplings.

Under certain circumstances, e.g. occasional or long-term movement, it may be possible to allow for increased expansion and contraction, but this should not be attempted without first contacting Viking Johnson.

Stepped couplings permit the same total expansion movement as straight couplings. However, pressure thrust may act on the stepped coupling causing the stepped coupling to move along the pipe with repeated expansion movement. Restraint for the coupling will be required.

	Maximum Relative Pipe Movement, Y-X (all sizes)
Couplings	10mm
Flange Adaptors	5mm

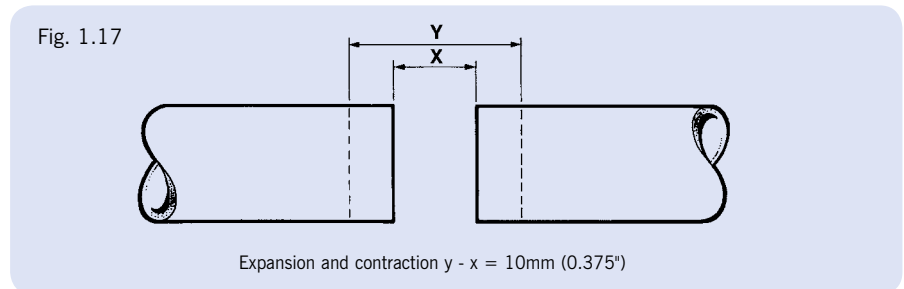

Pipe End Preparation

As stated earlier in System Overview (Page 7 - Pipe Surface Finish and Pipe Tolerances) it is important to remember:

- a) Within the area of the seal, pipe surfaces should be round, clean, smooth and free from bumps, dents, score marks, flat spots etc.
- b) Tolerances Should be in accordance with industry standards / specifications, if pressure ratings are to be maintained.

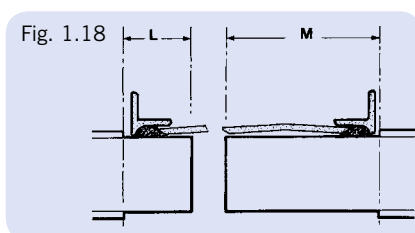

In the Pipe End Preparation Table (Table 1.6) dimension L is the distance back from the end of the pipes which must be rounded where necessary to meet the tolerances required. It is also the distance back from the end of the pipe from which any pipe wrapping should be removed to permit coupling assembly.

This applies equally to coupling sleeves with or without locating plugs.

Where it is required to slide the coupling completely on to one pipe end, any wrapping must be cut back or obstructions removed, for minimum distance M.

Table 1.6

PIPE END PREPARATION TABLE		
Sleeve Length	Dimension L for normal coupling assembly	Dimension M for closing connections (wrapping cut back)
100mm	100mm	150mm
150mm	150mm	225mm
178mm	150mm	250mm
254mm	200mm	300mm

Couplings

Straight Couplings are used for joining pipes of the same material or pipes of different materials but having the same outside diameter.

Available in 3mm size increments from DN350 (19") nom. up to DN5000 (200") nom. in standard form.

Couplings can be supplied with removable locating plug.

Heavy Duty Couplings, with strengthened end rings and sleeves are available for higher working pressures.

Long Sleeve Couplings, to take up larger pipe end gaps or cutting inaccuracies can also be supplied.

When using couplings, care must be taken to ensure that pipes are within the accepted tolerances, if pressure ratings are to be maintained.

When used on coated pipe, thickness of coating must be considered to be in **addition** to the pipe outside diameter.

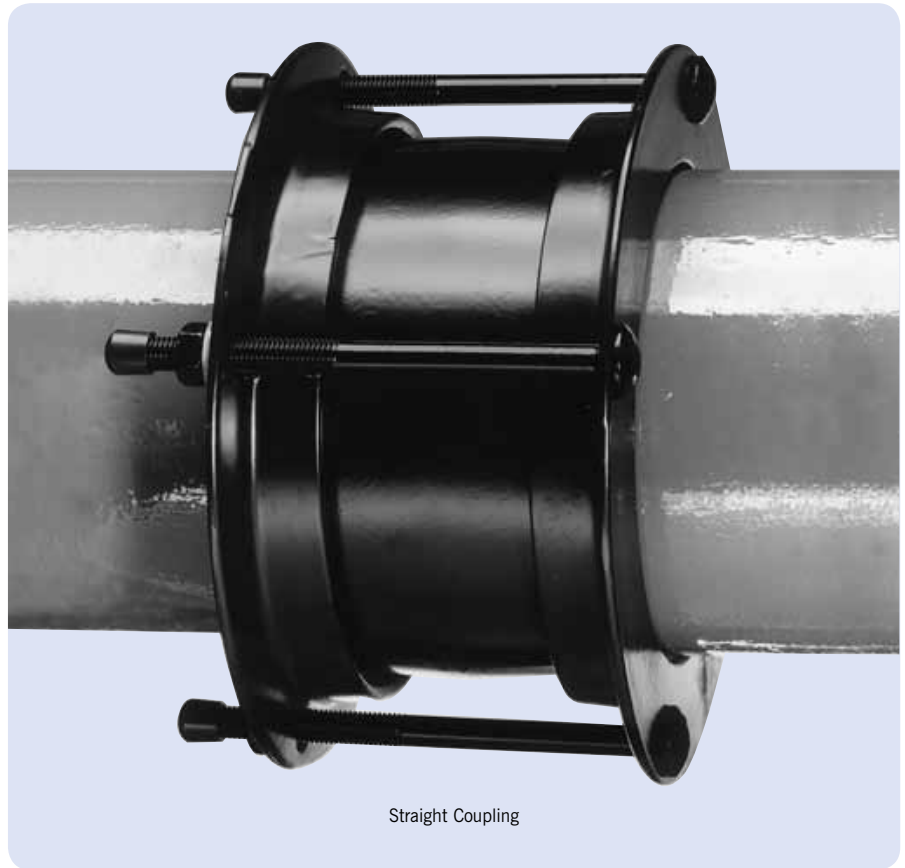

Bolts

Sheraplex coated bolts are supplied as standard. Galvanised or stainless steel bolts are also available. (Some products may have a limited range of bolt coatings for performance reasons.)

Locating Plugs

Locating plugs are manufactured from carbon steel as standard, zinc plated. They are also available in stainless steel.

Marine Couplings

Couplings specified for marine use are supplied complete with galvanised bolts, zinc plated locating plugs and Grade G nitrile gaskets.

Heavy Section Couplings

Heavy duty couplings with strengthened end rings and sleeves are available in sizes from DN250 (10") nom.

Coupling Sleeve Design

Within the range of Dedicated couplings there are variations of centre sleeve design, depending on the size and application.

Standard Sleeve

There are three types of standard sleeve for differing pipe sizes: (see Fig. 1.19)

- a) Steel plate sleeve
- b) Ductile iron sleeve
- c) Hot rolled section sleeve

Coupling sleeve design is dependent on diameter and at the discretion of Viking Johnson.

These standard sleeves do not have an integral centre register within the sleeve, enabling couplings to be slipped back along the pipe for pipe cleaning, repair and maintenance.

NOTE

Viking Johnson Flexible couplings do not resist longitudinal thrust loadings, and pipe pull-out will occur unless the loads are restrained by other means.

Fig. 1.19

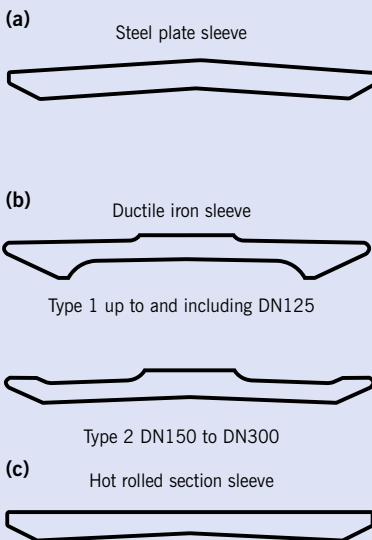

Stepped Couplings



Stepped Couplings are used to connect pipes of different outside diameters and/or pipes of different materials.

Pressure Rating

Pressure ratings for stepped couplings are equivalent to either:

- the rating specified in the straight coupling schedules for the larger of the two pipe sizes involved, or
- the lower of the individual pressure rating of the two.

Coupling Movement

When stepped or wide range couplings are used to join pipes of different outside diameters, it is essential to ensure that the stepped coupling cannot be forced along the smaller diameter pipe by internal pressure forces. This does not normally apply to the standard range of stepped couplings using expanded sleeves in a below ground service at moderate pressures. This is particularly important above ground and/or where a stepped coupling is used as an expansion joint. Regular inspection of the coupling position against a previously applied mark is strongly recommended, especially in above ground installations. (See also Pressure Forces, page 8).

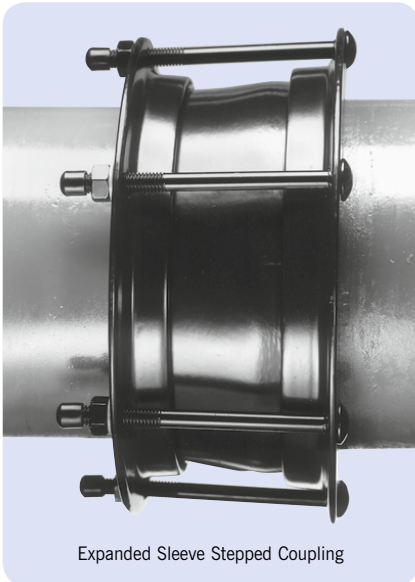

Stepped Coupling Sleeve Design

To accommodate the variety of sizes and combinations required, the centre sleeve of stepped couplings will be one of the three basic designs:

A. Expanded Sleeve

For the standard stepped connections (same nominal size, different materials), an expanded one-part sleeve, made as a casting or of rolled steel, is normally supplied (see Fig. 1.25a).

B. Fabricated Sleeve

For non-standard connections, where the difference in pipe diameters is not excessive, a two-part welded sleeve is fabricated from rolled steel. (Fig. 1.25b)

C. Make-Up Ring Sleeve

Where large steps between pipe sizes are required, a three-part welded sleeve is fabricated with studs fitted to the centre plate of the coupling instead of bolts. (Fig. 1.25c).

NOTE

For non-standard couplings the customer is encouraged to ask for an overall dimension drawing of the stepped coupling offered.

NOTE

Viking Johnson Flexible couplings do not resist longitudinal thrust loadings, and pipe pull-out will occur unless the loads are restrained by other means.

Fig. 1.25

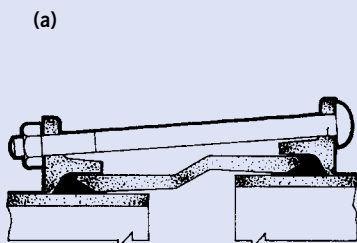

Expanded sleeve

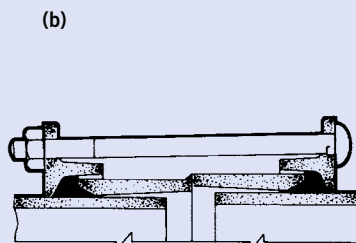

Fabricated sleeve

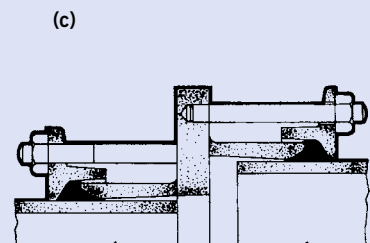

Make-up ring sleeve

Flange Adaptors

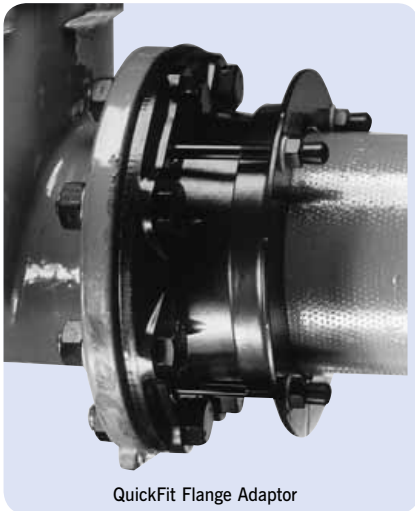

QuickFit Flange Adaptor

Flange adaptors are used to enable plain-ended pipe to be connected either to flanged pipe or to flanged valves and other fittings.

Raised Face Flanges

Viking Johnson flange adaptors are provided with flat mating faces. These are suitable for bolting to both flat and raised faces. The same gasket loading characteristics can be obtained as with a raised face assembly. To obtain a satisfactory seal, the radial contact dimension or ledge (K on Fig. 1.20) should be a minimum of 8mm.

Pressure Ratings

Viking Johnson flange adaptors are supplied to suit the pressure rating of the flange, unless specifically ordered otherwise. The overall pressure rating of the assembled adaptor will be equal to that of the lower rated component, either pipe or flange. e.g. PN10 flange adaptors have a flange rated at a working pressure of 10bar (150 psi). The coupling component of the flange adaptor will invariably have a higher pressure rating than the flange.

Dedicated Flange Adaptors

Are available in four basic forms with different sleeve designs:

Straight Sleeve

The standard form of flange adaptor has a straight sleeve and a flat face. (Fig. 1.21).

Expanded Sleeve (See note (i))

Specifically for use with very thick walled pipe such as asbestos cement or concrete, the expanded sleeve can also be used when the nominal sizes of the flange and the pipe are different (e.g. connecting DN350 (14") pipe to a DN300 (12") valve). See Fig. 1.22.

Typical Dimensions

Nom. flange size:

> DN300 (12")

B= 160mm

H= 57mm

B= 235mm

H= 82mm

Always confirm dimensional details before ordering.

Tapped Flange (See note (i))

As an alternative to the expanded sleeve, mismatched components may be joined using a tapped flange (Fig. 1.23). Studs, instead of flange bolts, are used to make the connection to the mating flange. Dimension B on Fig. 1.23 varies with the flange thickness C, relative to the tapping diameter. (This design is not suitable for some flange arrangements.)

'S' Bore

Flange adaptor with full flange faces suitable for use with wafer style (butterfly) valves are available see Fig. 1.24.

Fig. 1.20

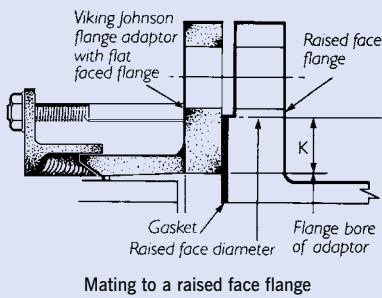

Mating to a raised face flange

Fig. 1.21

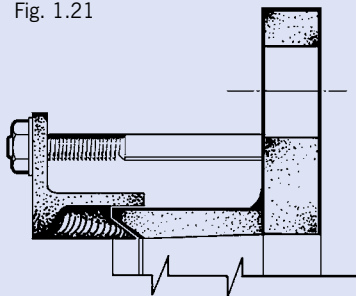

Straight sleeve

Fig. 1.23

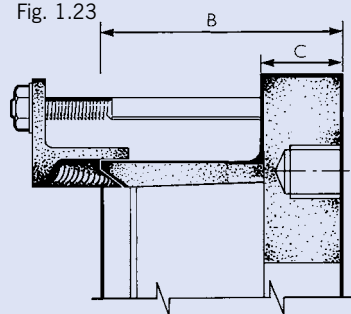

Tapped flange

Fig. 1.22

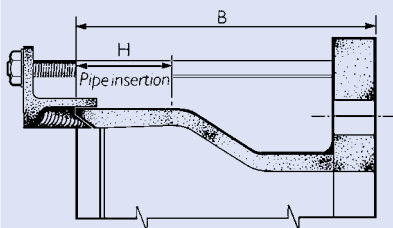

Expanded sleeve

Fig. 1.24

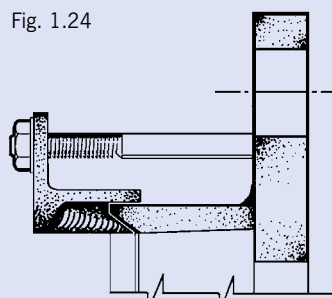

'S' bore flange

NOTE

(i) Customer approval of the supply of this design is generally sought prior to purchase.

NOTE

Viking Johnson Flexible couplings do not resist longitudinal thrust loadings, and pipe pull-out will occur unless the loads are restrained by other means.

Flange Comparison Chart

Nominal Size	Table	Diameter		P.C.D.		Hole Dia.		Bolt Dia.		No. Bolts
		mm	inch	mm	inch	mm	inch	mm	inch	
DN80/3"	PN10/16	200	7.9	160	6.3	18	0.7	16	0.625	8
	BS10 ADE	184	7.25	146	5.75	17	0.688	16	0.625	4
	ANSI 125/150	190	7.5	152	6	19	0.75	16	0.625	4
DN100/4"	PN10/16	220	8.67	180	7.1	18	0.7	16	0.625	8
	BS10 AD	216	8.5	178	7	17	0.688	16	0.625	4
	BS10 E	216	8.5	178	7	17	0.688	16	0.625	8
	ANSI 125/150	229	9	191	7.5	19	0.75	16	0.625	8
DN150/6"	PN10/16	285	11.22	240	9.45	22	0.875	20	0.79	8
	BS10 A	279	11	235	9.25	17	0.688	16	0.625	4
	BS10 D	279	11	235	9.25	17	0.688	16	0.625	8
	BS10 E	279	11	235	9.25	22	0.875	19	0.75	8
	ANSI 125/150	279	11	241	9.5	22	0.875	19	0.75	8
DN200/8"	PN10	340	13.4	295	11.6	22	0.875	20	0.79	8
	PN16	340	13.4	295	11.6	22	0.875	20	0.79	12
	BS10 AD	337	13.25	292	11.5	17	0.688	16	0.625	8
	BS10 E	337	13.25	292	11.5	22	0.875	19	0.75	8
	ANSI 125/150	343	13.5	298	11.75	22	0.875	19	0.75	8
DN250/10"	PN10	395	15.55	350	13.78	22	0.875	20	0.79	12
	PN16	405	15.55	355	14	26	1.03	24	0.95	12
	BS10 AD	406	16	356	14	22	0.875	19	0.75	8
	BS10 E	406	16	356	14	22	0.875	19	0.75	12
	ANSI 125/150	406	16	362	14.25	25	1	22	0.875	12
DN300/12"	PN10	445	17.5	400	15.75	22	0.875	20	0.79	12
	PN16	460	18.2	410	16.15	26	1.03	24	0.95	12
	BS10 A	457	18	406	16	22	0.875	19	0.75	8
	BS10 D	457	18	406	16	22	0.875	19	0.75	12
	BS10 E	457	18	406	16	25	1	22	0.875	12
	ANSI 125/150	483	19	432	17	25	1	22	0.875	12
DN350/14"	PN10	505	19.88	460	18.11	22	0.875	20	0.79	16
	PN16	520	20.47	470	18.50	26	1.03	24	0.95	16
	BS10 A	527	20.75	470	18.5	25	1	22	0.875	8
	BS10 DE	527	20.75	470	18.5	25	1	22	0.875	12
	ANSI 125/150	533	21	476	18.75	29	1.125	25	1	12
DN400/16"	PN10	565	22.24	515	20.28	26	1.03	24	0.95	16
	PN16	580	22.83	525	20.67	30	1.20	27	1.07	16
	BS10 ADE	578	22.75	521	20.5	25	1	22	0.875	12
	ANSI 125/150	597	23.5	540	21.25	29	1.125	25	1	16
DN450/18"	PN10	615	24.21	565	22.24	26	1.03	24	0.95	20
	PN16	640	25.20	585	23.03	30	1.20	27	1.07	20
	BS10 AD	641	25.25	584	23	25	1	22	0.875	12
	BS10 E	641	25.25	584	23	25	1	22	0.875	16
	ANSI 125/150	635	25	578	22.75	32	1.25	29	1.125	16
DN500/20"	PN10	670	26.38	620	24.41	26	1.03	24	0.95	20
	PN16	715	28.15	650	25.59	33	1.30	30	1.20	20
	BS10 A	705	27.75	642	25.25	25	1	22	0.875	12
	BS10 DE	705	27.75	642	25.25	25	1	22	0.875	16
	ANSI 125/150	698	27.5	635	25	32	1.25	29	1.125	20
DN600/24"	PN10	780	30.71	725	28.54	30	1.20	27	1.07	20
	PN16	840	33.07	770	30.31	36	1.42	33	1.30	20
	BS10 A	826	32.5	756	29.75	29	1.125	25	1	12
	BS10 D	826	32.5	756	29.75	29	1.125	25	1	16
	BS10 E	826	32.5	756	29.75	32	1.25	29	1.125	16
	ANSI 125/150	813	32	749	29.5	35	1.375	32	1.25	20

Introduction

The quality and performance of the gaskets is a crucial factor in the efficiency of any compression-fit pipe joint. It is the gasket which absorbs the forces applied by the expansion and contraction of the pipes, the angular movements and even the weight of the pipe itself. To do this successfully, the gasket must retain its flexibility and compressive stress throughout its operational life.

Viking Johnson gaskets are made in accordance with BS EN 681 for water and BS EN 682 for gas, which specifies stringent requirements for physical and chemical properties, aimed at giving the best possible long-term performance.

Gasket Types

Fitted Gaskets

All straight couplings, stepped couplings and flange adaptors in the QuickFit, MegaFit, UltraGrip and MaxiFit products, are normally supplied ready-assembled with the gaskets already in position. Making assembly of the product quicker and easier.

Removal of the gaskets prior to or during assembly of the coupling is neither necessary, nor recommended.

Unfitted Gaskets

Wedge-shaped gaskets are supplied as standard with Dedicated couplings, stepped couplings and flange adaptors in sizes DN350 (14") and over. Unfitted gaskets are always stretched onto the pipe during installation.

Bonded Gaskets

Certain Viking Johnson products, such as EasiClamp, EasiTee etc, are supplied with waffle type gaskets that are bonded into position. These gaskets are not replaceable.

Gasket Grade Selection

Viking Johnson products offer a variety of gasket grades to suit the widest possible range of applications. In order to ensure maximum gasket life in the intended application, proper selection is essential, See table on page 21.

Many factors need to be considered in deciding on the best grade for a specific service. Temperature is the primary consideration, with type and concentration of the product carried, duration and continuity of service also to be considered. Temperatures higher than the maximum quoted for each grade will lead to accelerated deterioration of the gaskets.

Fluctuating and / or Elevated Temperature

Whilst gasket compounds used in coupling type products may be capable of accommodating fluctuating or elevated temperatures (>60°C) the relaxation rate of the elastomeric seals will increase, thus reducing the life expectancy of the joint. The failure mode is likely to be leakage of the seal between the coupling and pipe outside diameter, which, on the basis that there is sufficient travel on the bolts and the metal components are not touching, can be rectified by tightening the bolts. In the event that the metal components are touching, replacement of the gaskets in the coupling will be required.

Standard Gaskets

Unless otherwise specified, Viking Johnson couplings are supplied with Grade E (EPDM) gaskets as standard in all sizes. Grade E is suitable for potable water, drainage and sewage applications but is NOT suitable for use with natural gas, hydrocarbon fuels and lubricants. For gas, oil and fuel applications Grade G (nitrile) should normally be specified.

For QuickFit and Dedicated range only: where special usage conditions apply, eg. special chemical requirements, low flammability (eg. in confined spaces such as tunnels) or higher temperature resistance, a range of non-standard gasket materials is available, normally to special order. For further information on gasket suitability, contact Viking Johnson.

Summary of Gaskets

Grade E - Ethylene Propylene (EPDM)
BS EN 681-1 WRAS approved.

Colour flash: Green

Temperature range: -40°C to +90°C (-40°F to 195°F) - (Note 1)

Suitable for: potable water, sewage, many strong and oxidising chemicals, some food applications.

NOT suitable for: Gas petroleum products, oily compressed air or hydrocarbon fuels and lubricants.

Grade G - Nitrile (NBR)
BS EN 682 Type G.

Colour flash: Silver

Temperature range: -20°C to +100°C (-4°F to 212°F) - (Note 1)

Suitable for: natural gas, petroleum products, low aromatic fuels (generally <30% aromatic content), oily compressed air and sewage applications.

NOT suitable for: potable water.

SPECIALIST GASKETS - AVAILABLE ON REQUEST FOR DEDICATED AND QUICKFIT COUPLING RANGE ONLY

Grade V - Polychloroprene

Colour flash: Yellow

Temperature range: -30°C to +90°C (-22°F to 195°F) - (Note 1)

Suitable for: Good resistance to ageing, weathering, ozone, oxidation, acids, most inorganic chemicals, vegetable and animal fats. Low flammability.

NOT suitable for: chlorinated hydrocarbons, aromatic solvents.

Grade C - Epichlorhydrin

Colour flash: White with 'ECO' superimposed.

Temperature range: -45°C to +110°C (-50°F to 230°F) - (Note 1)

Suitable for: petroleum products, including low aromatic fuels (<30% aromatic content) and oily compressed air.

NOT suitable for: Aqueous media.

Grade A - Polyacrylic

Colour flash: Purple

Temperature range: -10°C to +130°C (15°F to 265°F) - (Note 1)

Suitable for: Hot transformer and lubricating oils, petroleum products and low aromatic fuels (<30% aromatic content).

NOT suitable for: Water and steam.

Grade O - Fluoroelastomer

Colour flash: Blue

Temperature range: -5°C to +180°C (25°F to 350°F) - (Note 1)
(+100°C (212°F) on water and steam)

Suitable for: Petroleum products, aromatic fuels, hydraulic fluids, oxidising acids and organic liquids.

NOT suitable for: Ketones.

Grade L - Silicone

Colour flash: Red gasket material

Temperature range: -60°C to +200°C (-75°F to 395°F) (dry heat), - (Note 1)
-60°C to +120°C (-75°F to 250°F) (wet heat) - (Note 1)

Suitable for: Dry heat conditions, neutral aqueous and some chemical solutions.

NOT suitable for: Petroleum based products or high mechanical abuse applications.

Note 1: Use on applications with fluctuating and / or elevated temperatures may require regular maintenance to re-tighten the bolts and must be included in any maintenance schedule.

Storage

Stored correctly, gaskets maintain full operational performance and maximum life expectancy. Please observe the following storage conditions.

- Store in a cool dark place and, where possible, in black polythene sacks which exclude light, especially ultra-violet.
- Store away from sunlight, electrical discharges and sparking electric motors.
- Storage temperature should be below 20°C (70°F) and preferably below 15°C (60°F).
- Always store gaskets in an unstressed condition - never hang on hooks, nails, handrails, etc., even for a short time.

Safety Note

Rubber gaskets should never be disposed of by burning, as harmful by-products can be produced. Never handle incinerated or fire damaged gaskets without proper protective clothing.

Lubrication

IMPORTANT: It is strongly recommended that unfitted gaskets are lubricated prior to fitting. Failure to apply lubricant can cause difficulty in fitting and may result in gasket creep under load. This may cause bolt torques to drop, thus necessitating re-tightening.

Renewal of Gaskets

If, for any reason, it becomes necessary to renew a gasket in a Viking Johnson coupling or flange adaptor (where the product cannot be fully dismantled and removed from the pipe), a strip of the correct section gasket material should be cut square about 6mm longer than the pipe circumference and inserted into the tapered recess of the sleeve. Care should be taken that the cut ends of the gasket butt together before bolting up the end rings - glueing the cut ends together prior to bolt-up may assist in this. Gasket strip can be purchased as strip from Viking Johnson.

NOTE: Reference should be made to the grade of gasket material required and coupling type. Alternatively, use a gasket of the same cross-section but a larger diameter and cut this squarely to produce a strip sufficiently long to wrap around the pipe.

Chemical Resistance

The various gasket grades mentioned in this section, in addition to having different operating temperatures, are resistant to different chemicals. When designing a piping system it is important to verify that the correct gasket grade is specified.

Product Coatings

A number of factory applied coatings are available to ensure full protection against corrosion:

Rilsan Nylon 11

Rilsan Nylon 11 is a thermoplastic polyamide powder coating produced from a renewable raw material of plant origin (Castor Oil). Applied by dipping in a fluidised bed, it forms a durable protection with excellent resistance to impact, abrasion, weathering, many chemicals and with good thermal stability and flexibility. Rilsan Nylon 11 provides all the corrosion protection you need for the majority of buried and above ground service applications and eliminates the need for any further protection, such as on-site wrapping. For specific chemical resistance information, please check the chemical resistance chart at the end of the section, or ask for specific recommendations.

Rilsan Nylon 11 is both WRAS and DWI approved, is suitable for use with potable water and has a maximum operating temperature rating of 90°C (195°F) for water service.

Site repair of localised surface damage, e.g. through careless handling, is straightforward using the special two-pack repair kit.

Most Viking Johnson products are supplied with this protection as standard. Rilsan Nylon 11 Black meets the requirements of WIS 4-52-01 Part 1 and EN 10310 and is our standard Rilsan coating colour, since this provides the optimum resistance to sunlight exposure during storage and provides a responsible coating solution that also helps to protect our environment.

Fusion Bonded Epoxy (FBE)

Many Viking Johnson products may be specified with FBE coating, such as 3M's Scotchkote 206N. FBE coatings are thermosetting compounds and offer excellent corrosion protection and resistance to a wide range of organic and inorganic chemicals. Many may be used in contact with potable water. FBE coatings generally offer good resistance to soil compaction and cathodic disbondment. Continuous maximum temperature capability of 90°C (195°F) on water service. Site repair is possible using special repair packs.

Galvanising

A hot dip process giving a zinc coating in conformity with BS.729. Certain Viking Johnson products may be specified with this coating. Other specialist coatings can be supplied according to customer requirements.

Shopcoat

A primer paint for transit.

Bolt Coatings

Depending on product and market/application, bolts may be coated in the following corrosion-protection systems:

- | | |
|-----------------|---|
| Sheraplex | - low friction compound coating based on sheradising and fluoropolymer |
| Galvanised | - a metallic zinc coating |
| Flurene 177 | - a low friction coating, mainly used for AquaGrip and EasiTee products |
| Stainless steel | - bolts may be supplied in either grade 304 or 316 stainless steel |
| Dacromet | - anti-galling coating for stainless steel nuts |

Chemical Resistance Chart

CHEMICAL COMPOSITION	GASKET / GRADE	RILSAN	SCOTCHKOTE	CHEMICAL COMPOSITION	GASKET / GRADE	RILSAN	SCOTCHKOTE
Acetic Acid, up to 10%	E,G,V	✓	✓	Hydrogen, Gas	E, G, V	✓	✓
Acetone	E	✓	✓	Hydrogen Sulphide	E, V	✓	✓
Acetylene	E,G	?	?	Kerosene	G, A, O	✓	✓
Air, oil free	E,G	✓	✓	Ketones	E	✓	✓
Air, oily	G, A	✓	✓	Lubricating Oil, Refined	G, O	✓	✓
Alcohol - butyl, ethyl, methyl	E, G	✓	✓	Methane	G, A, O	✓	✓
Aluminium Hydroxide	E	✓	?	Methyl Ethyl Ketone	E	✓	✓
Alums, all types	E, G, V	✓	✓	Mineral Oils	G	✓	✓
Ammonia Gas, cold	E, G, V	✓	✓	Naphtha	O	✓	✓
Ammonium Bicarbonate	E, G	✓	✓	Natural Gas	G	✓	✓
Ammonium Nitrate	E, G	✓	✓	Nitric Acid, to 10%	E	?	✓
Animal Oils/Fats	G	✓	✓	Nitrogen	E, G, V	✓	✓
Aviation Fuel	G, C, O	✓	✓	Oil, Crude Sour	G, O	✓	✓
Benzene	O	✓	✓	Oxygen	E	✓	✓
Blast Furnace Gas	O	?	?	Ozone	E	✓	✓
Bleach Solutions	E	✓	✓	Petroleum Oils	G, O	✓	✓
Brine	E, G, V	✓	✓	Phenol (Carbolic Acid)	O	✓	✓
Butane Gas	G, V	✓	✓	Polyvinyl Acetate	E	✓	✓
Calcium Chloride	E, G, V	✓	✓	Potassium Chloride	E, G, V	✓	✓
Calcium Hydroxide	E, G, V	✓	✓	Potassium Hydroxide	E, V	✓	✓
Calcium Hypochlorite (Bleach)	E	✓	✓	Potassium Permanganate	G	?	?
Carbon Tetrachloride	O	?	✓	Propane Gas	T	✓	✓
Caustic Soda	E, V, G	✓	✓	Sewage	E, G, V	✓	✓
Chlorine (dry)	E	?	?	Sodium Bicarbonate	E, G, V	✓	✓
Coke Oven Gas	G, O	?	?	Sodium Carbonate	E	✓	✓
Copper Sulphate	E, G, V	✓	✓	Sodium Chloride	E, G, V	✓	✓
De-ionised Water	E, G, V	✓	✓	Sodium Hydroxide, to 50%	E, V	✓	✓
Detergents	E, G, V	✓	✓	Sodium Hypochlorite, to 20%	E, G	✓	✓
Developing Fluids	G, V	?	?	Styrene	O	✓	?
Diesel Oil	G, O	✓	✓	Sulphuric Acid, to 25%, 66°C (150°F)	E	✓ (10%)	✓
Ethane	G	✓	✓	Toluene	O	✓	✓
Ethylene	G, O	✓	✓	Turpentine	G	✓	✓
Ethylene Glycol	E, G, V	✓	✓	Vegetable Oils	E, G	✓	✓
Fuel Oil	G, O	✓	✓	Vinyl Acetate	E	?	?
Gasoline, Leaded & Unleaded (<30% aromatics)	G, O	✓	✓	Vinyl Chloride	O	?	?
Glycerine (Glycerol)	E, G, V	✓	✓	Water, to 90°C (195°F)	E	✓	✓
Glycols	E, G, V	✓	✓	Water, Potable	E	✓	✓
Hexane	G, O	✓	✓	Water - Waste, Seawater	E, G, V	✓	✓
Hydrochloric Acid, Cold to 50%	E, O	?	✓	White Spirit	G	✓	✓

For advice on any chemical not listed here, please contact Viking Johnson for further details
 ✓ Good Resistance ? Contact Viking Johnson for further advice



To visit our Video Library go to:
<http://www.youtube.com/user/CraneBSU>



46-48 WILBURY WAY
HITCHIN, HERTFORDSHIRE
SG4 0UD. UNITED KINGDOM
TELEPHONE: +44 (0)1462 443322
FAX: +44 (0)1462 443311
EMAIL: info@vikingjohnson.com



www.vikingjohnson.com



ISO 14001 • EMS 51874



ISO 9001 • FM 00311



www.flowoffluids.com

Visit www.flowoffluids.com
to order your copy of the
New Technical Paper 410.

- Designed and manufactured under quality management systems in accordance with BS EN ISO 9001.
- Environmental Management System accredited to ISO 14001.
- For full terms and conditions, please visit our website.

Every effort has been made to ensure that the information contained in this publication is accurate at the time of publishing. Crane Ltd assumes no responsibility or liability for typographical errors or omissions or for any misinterpretation of the information within the publication and reserves the right to change without notice.

DR6433_09_2012